



8051 5.1 Compressor

User Guide

527-357

Issue 2

© 2005 AMS Neve Ltd own the copyright of all information and drawings contained in this manual which are not to be copied or reproduced by any means or disclosed in part or whole to any third party without written permission.

As part of our policy of continual product improvement, we reserve the right to alter specifications without notice but with due regard to all current legislation.

Disclaimer: The information in this manual has been carefully checked and is believed to be accurate at the time of publication. However, no responsibility is taken by us for inaccuracies, errors or omissions nor any liability assumed for any loss or damage resulting either directly or indirectly from use of the information contained within it.

HEAD OFFICE

AMS NEVE LTD • BILLINGTON ROAD • BURNLEY
LANCS BB11 5UB • ENGLAND
TELEPHONE: +44 (0) 1282 457011 • FAX: +44 (0) 1282 417282

LONDON OFFICE

TELEPHONE: +44 (0) 20 7916 2828 • FAX: +44 (0) 20 7916 2827

NORTH AMERICAN OFFICES

AMS NEVE INC., NEW YORK
TEL: +1 (212) 965 1400 • FAX: +1 (212) 965 9306
AMS NEVE INC., HOLLYWOOD
TEL: +1 (818) 753 8789 • FAX: +1 (818) 623 4839

e-mail: info@ams-neve.com
<http://www.ams-neve.com>

Contents

Introduction	1
Dimensions	2
Rack Mounting and Cooling	2
Power Requirements	2
Mains Supply	2
Rear Panel Connectors	3
Compressor Controls	4
LFE Filter (Filter to Channel)	4
Bypass	5
Sidechain Link	6
Sidechain Filter	6
Control Link	7
SC Trims and Threshold	8
EXT Control	9
Threshold	10
Gain Makeup	10
Ratio	10
Attack	11
Recovery	11
Gain Reduction Meters	11
Key Input	12
Key Filter	12
Bias Control	12
Output Level	12
Power	12
Mastering Compressor Controls (AM5292)	13
8051 Compressor - 88R(S) Console mounted	14
I/O Wiring (AM5052 & AM5265)	15
Specifications	16
8051 Block Diagram	17

Introduction

The 8051 is an analogue compressor that provides six transformer balanced audio paths complemented by two sidechains and a key input. Input and output to the sidechains is assignable to and from the six channels. Assignable LFE filters on the input and sidechains along with the key input provide integrated bass management.

Flexible sidechain routing, trimming and filtering make this a powerful and responsive tool for surround mixing.

The 8051 uses the same feedback topology as the 33609 compressor and includes the same transformers, diode-bridge gain control and discrete power amplifiers in the audio path.



8051 5.1 Compressor

Dimensions

Units	U	Depth mm (inches)	Height mm (inches)	Approx. Weight kg (lbs)
8051 Compressor (AM4851 and AM5292) not including mains plug	3	500 (20)	135 (5.25)	10.5 (23)

Rack Mounting and Cooling

The rack units should be installed in a 19" cabinet with access to the front and rear.

No specific air conditioning is required for the racks, provided that there is a free flow of air through the rack from front to back, and that the ambient air is maintained below 30 degrees centigrade. Therefore the racks may be stacked.

Power Requirements

8051 Units	
Rated Voltage	100-250V AC
Rated Frequency	47-63 Hz
Rated Current	.25A at 250V
Primary Protection Fuse:	
Operating Voltage	250/110V
Fuse Rating and Type	T1.6A/T1.6A A/S Ceramic
Location	Rear Panel IEC Mains Connector

Mains Supply

The power supply unit is a universal input type therefore no mains operating voltage setting is required.

The CH (chassis) and 0V are linked externally.

See the rear panel layout for AM4851 & AM5292.

Rear Panel Connectors

 Mating connectors are not supplied with these units.

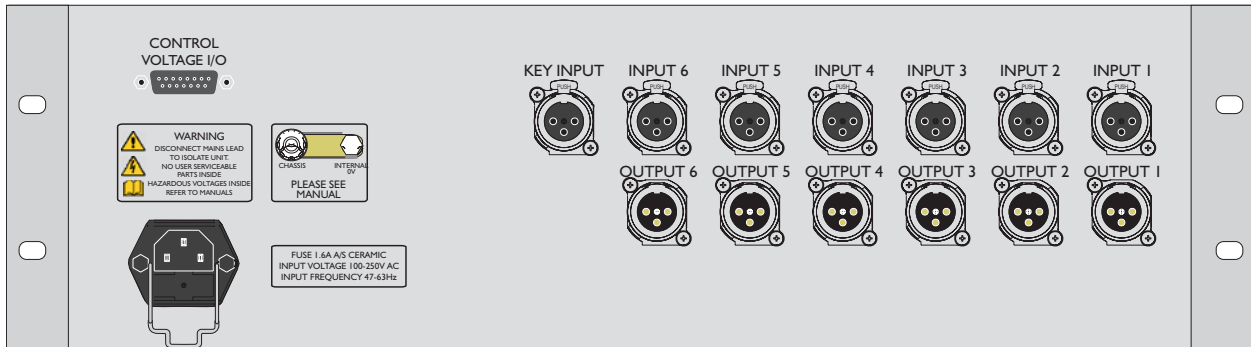

CONTROL VOLTAGE I/O - 15 Pin D-Type

KEY INPUT - XLR Socket

INPUT 1-6 - XLR Socket

OUTPUT 1-6 - XLR Plug

 These connectors apply to both the Standard and Mastering Compressor (AM4851 & AM5292).

 For I/O wiring on 88R(S) console mounted compressors (AM5052 & AM5265) see page 15.

Compressor Controls

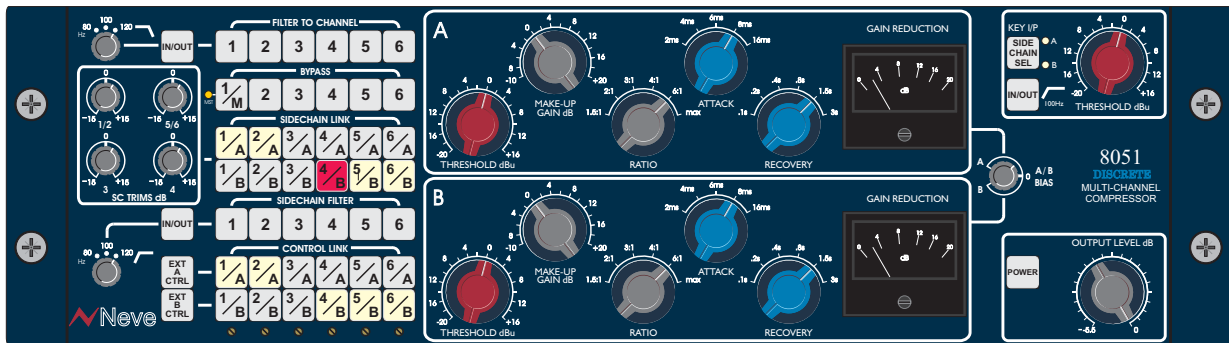

LFE Filter (Filter to Channel)

A 12dB/octave low-pass filter can be assigned to any one channel. This filter is applied directly to the input before the relay-bypass point, and its -3dB frequency is selectable from 80, 100 or 120Hz.

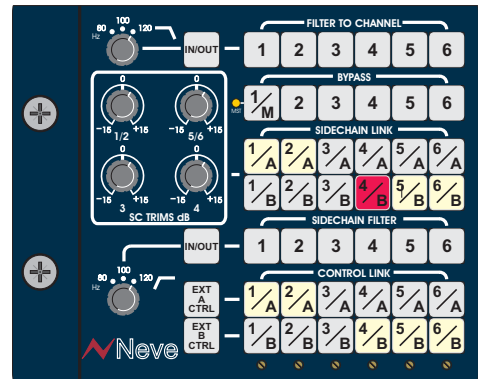

Bypass

All channels have relay bypass. Bypass is from the output of the LFE filter to the input of the Output Level Control *.

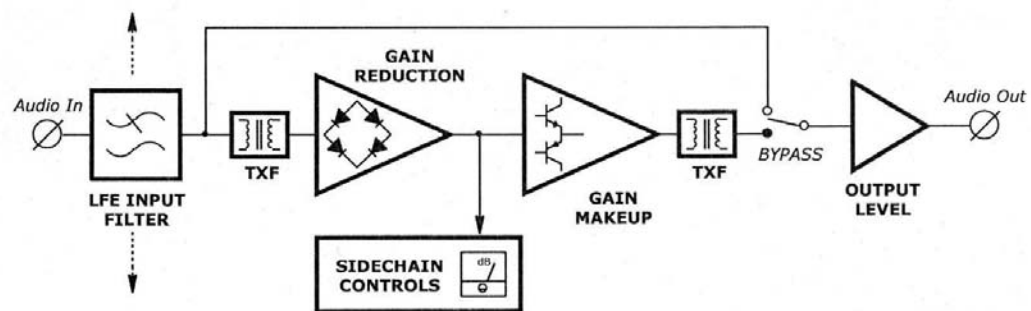
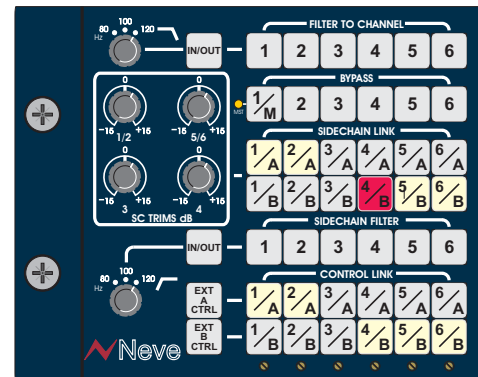

If a channel routed to a sidechain is bypassed, its connection to the sidechain is maintained. This means that other channels controlled by that sidechain are unaffected and allows a channel to control others without being compressed itself (as though it were another key input).

Two bypass modes are available, single or master. In single mode each switch bypasses its respective channel. In master mode all channels are controlled together from the channel 1 bypass button.

Master mode is toggled by pressing and holding the channel 1 bypass switch and is indicated by the **MST** LED to the left of channel 1 being lit. If individual channels are placed in Bypass mode, the Master Bypass function then becomes a Group Bypass control for the remaining channels.

 * In Master Mode individual channels can be deselected from the master group and will remain in local bypass indicated by permanently lit bypass buttons.

 * The elements outside the bypass loop are designed to be audibly transparent. Typical distortion in bypass is <math><0.0008\%</math> at 1kHz, typical 20Hz-20kHz band noise is <math><-90\text{dBu}</math>.

Sidechain Link

The sidechain link buttons route audio from each channel's sidechain audio path into one or both of the sidechain timing circuits. If a single channel's SC LINK A or B button is pressed, that channel will behave as a mono compressor.

If another channel is then linked to the same sidechain, the timing circuit responds to whichever channel is larger at any moment (taking into account the setting of the SC trim controls). The resulting control voltage is then applied equally to both channels, i.e. they behave as a stereo linked compressor.

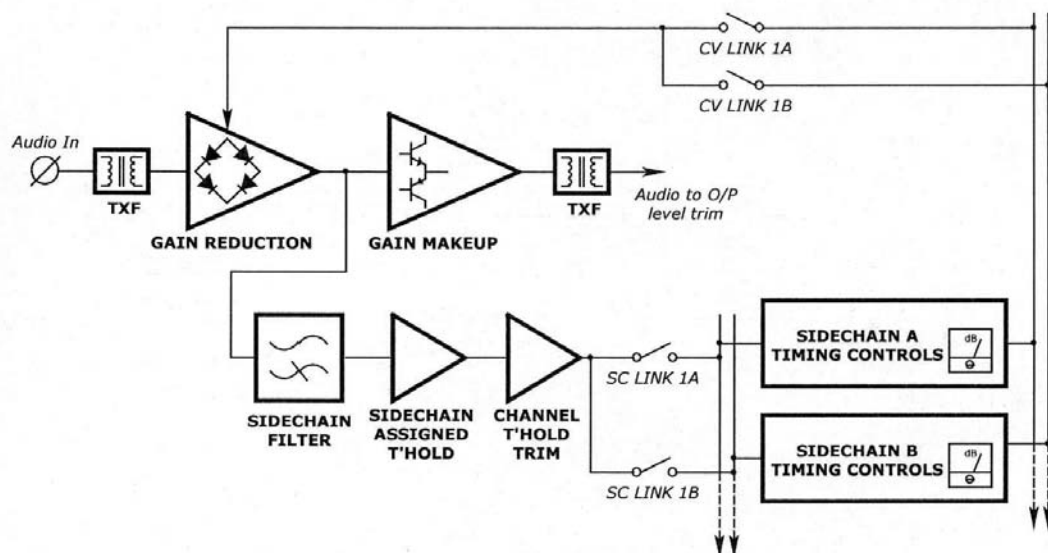

Sidechain Filter

Inserts a high-pass filter in the channel's sidechain path, preventing unwanted compression due to LFE content. The response is 12dB/octave, shelves at -20dB (this is required to maintain the sidechain's phase margin) and has a selectable -3dB frequency of 80, 100, or 120Hz.

Control Link

While the SC link buttons control the audio inputs to each sidechain, the CV link buttons choose where the D.C. control voltage generated by each sidechain is routed. The CV link buttons also determine which gain makeup control affects each channel, in the same way that the SC link buttons assign the threshold controls.

For the output of a sidechain to be correct, it must be fed back to the channels it is derived from. Pressing an SC link button will therefore illuminate the corresponding CV link button and lock it on.

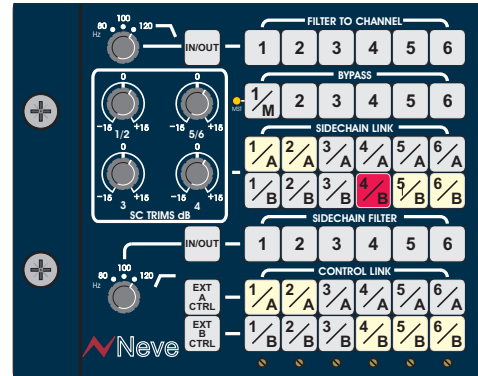

Most compressors apply gain reduction based entirely on the signal level at their inputs. A level detector examines the input and drives an output VCA that is assumed to have a complimentary response (a 'feed-forward' system). The 8051 uses a feedback topology, monitoring the output of each gain cell and continually adjusting the control voltage returned to give the required gain reduction.

This means that the control voltage linking has to follow sidechain linking to maintain a closed loop. Once this feedback is in place the sidechain output can be linked to other channels using the remaining unlit CV link buttons. These channels then follow the same dynamic envelope as the SC Linked channels, but without their audio content affecting the compression.

A channel may also have control voltage linked from both sidechains. In this case the sidechain providing the most gain reduction at any moment controls the channel, and the greater of the two gain makeup settings will be applied.

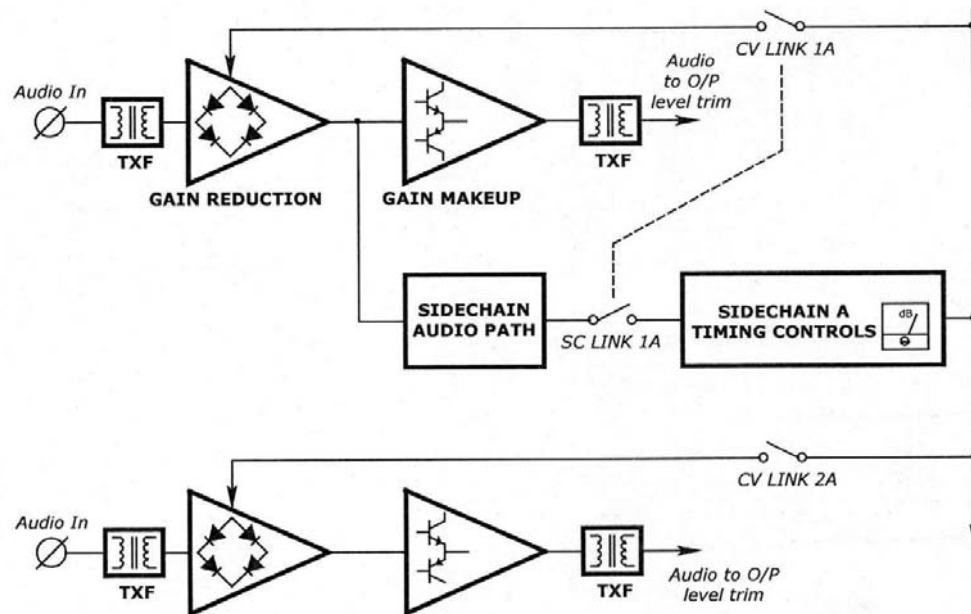

 The CV Link buttons are disabled unless either a channel or the key has been routed to the associated sidechain, or when in external mode.

SC Trims and Threshold

Thresholds for each channel are determined by sidechain path gain which is applied in two stages.

The two main threshold controls are first assigned to each channel with the SC Link buttons, providing a base threshold level for each of the sidechains. The SC Trim controls then allow threshold adjustment on individual channels of $\pm 15\text{dB}$, irrespective of how they are linked. The trims are grouped as two stereo pairs (channels 1/2 and 5/6) and two monos (channels 3 and 4).

Once above the sidechain's threshold level, the link button for the largest signal on that sidechain (after the threshold gain has been applied) illuminates red. Any signal that is above threshold and within 2dB of the dominant signal will also illuminate.

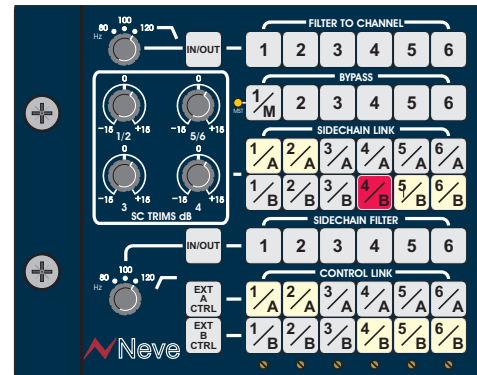

EXT Control

The EXT buttons provide an insert point in the control voltage signal, after the bias control but before routing back to the channels.

During normal operation the control voltages generated by the sidechain are internally connected to the CV Link switched for routing back to the channels. In EXT mode the control voltage is taken from the rear connector instead of the sidechain outputs, allowing the unit to be slaved from a second 8051 or 33609.

 There is no EXT Control with 88R(S) console mounted compressors (AM5052 & AM5265).

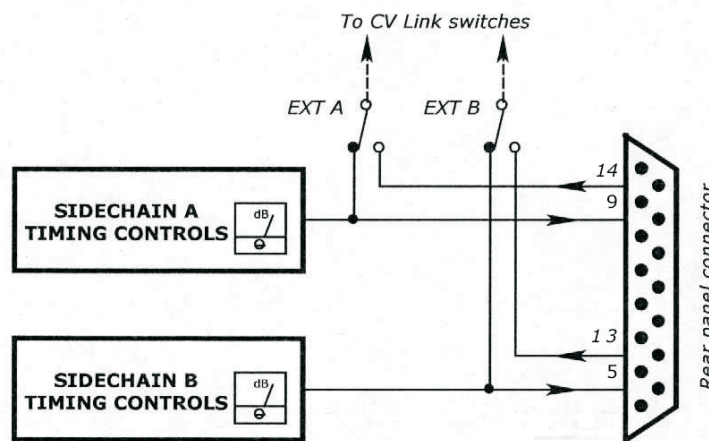

Pin	Function
1	0V Reference
9	CV send, sidechain A
12	Remote power-on
5	CV send, sidechain B
13	CV return, sidechain B
14	CV return, sidechain A
15	24V Reference

Short to pin 12 to pin 1 to take the unit out of standby mode remotely.

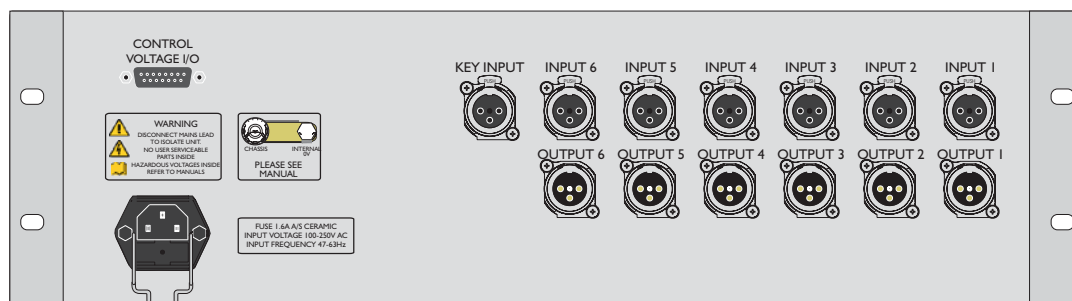

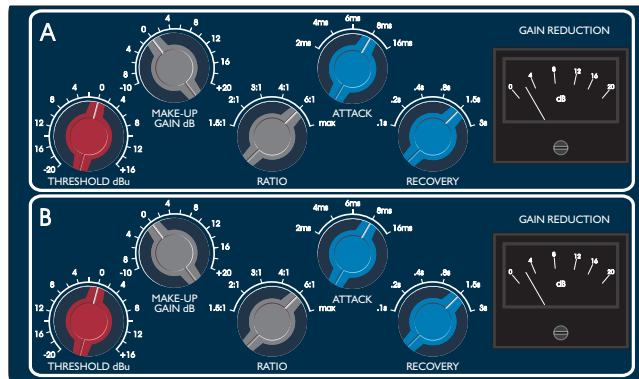

Threshold

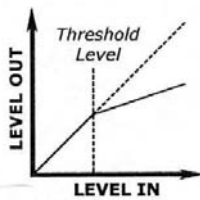

Threshold is the level above which compression begins. Each channel linked to a sidechain (using the SC Link buttons) takes that sidechain's threshold. If a channel is linked to sidechains A and B the lower value of the two controls is used. The threshold controls have a range of -20dBu to +16dBu, adjustable in 2dB steps. Each channel's threshold may be modified by up to ±15dB irrespective of its linking by using the SC Trim controls.

 A red LED indicator is provided in each sidechain link button. This indicates that a channel is above threshold, and either is the dominant signal or within 2dB of the dominant signal on that sidechain.

Gain Makeup



Gain Makeup is used to restore the average level or loudness of a compressed signal. Linking control voltage to a channel (with the CV Link buttons) assigns either the A or B Gain Makeup control to that channel. If control voltage from both sidechains is linked the larger of the two values is used; this is because the sidechain with the greater gain reduction will be controlling the channel. The gain applied is adjustable from -10 to +20dB in 2dB steps.

Ratio

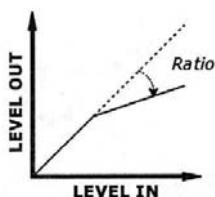

Ratio controls the amount of gain reduction applied as the input level increases.

At 2:1 for example, a change of 10dB at the input produces a change of 5dB at the output. Values available are 1.5:1, 2:1, 3:1, 4:1, 6:1, and 'max' (approximately 8:1).

The 8051 has a soft-knee characteristic, and its ratio gradually increases as the compression becomes heavier at all settings. The numbers given should therefore be considered average values.

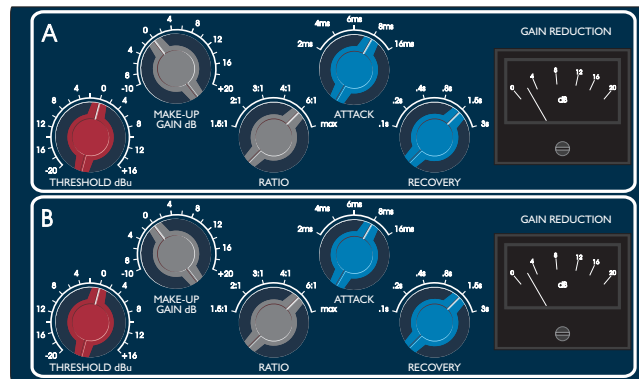

Attack

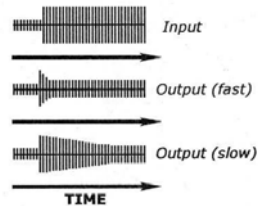

This is the time between a signal 6dB above the threshold level being applied, and the output signal falling to within 2dB of its final level. With slower attack settings compression is more dependant on the average signal level, while with faster settings it is more dependant on the peaks. Setting of 2ms, 4ms, 6ms, 8ms and 16ms are available.

Recovery

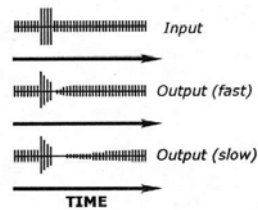

If a signal 6dB above the threshold has been applied for long enough that the output has reached its steady-state level, recovery is the time taken for it to get to within 2dB of its final level if the input is dropped by 6dB. Recovery compliments the attack control by filtering the control voltage; longer recovery times prevent pumping effects where gain reduction follows the program material too closely. Settings of 100ms, 200ms, 400ms, 800ms, 1.5s and 3s are available.

Gain Reduction Meters

Gain reduction meters are provided post the A/B Bias control and pre the CV Link routing buttons to show the level of attenuation being applied. The meters have 20dB f.s.d.

Key Input

A Key Input is provided to allow adjustable control from an external source. Like the sidechains the key input has a threshold level control ranging from -20 to +16 to set the intended level at which compression control is required.

It can be used in several ways:

- Injecting tone to provide a remotely variable base-level of compression on one or both sidechains.
- 'Ducking' from an audio source such as dialogue.
- When connected in parallel with one of the inputs, it allows that input to be routed onto both sidechains with different compression thresholds.

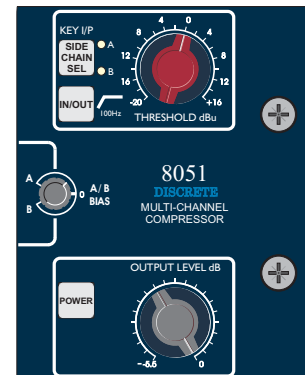

Key Filter

The key input is provided with a selectable 12dB/octave high-pass LFE filter, fixed at 100Hz.

Bias Control

The bias control is used to balance the control voltages from the two sidechains by applying up to 6dB of cut and boost, effectively modifying their ratios.

If only a single sidechain is in use, for example when used as a stereo compressor, the bias control allows ratio values between the standard settings to be selected with continuously variable control.

Output Level

This control provides a variable active pad across all six outputs, from 0dB to -5.5dB in 0.25dB steps. The pad is outside of the relay bypass loop and so always controls all six channels together in order to maximise the unit's output level without clipping.

Power

The power switch is illuminated dim red when the mains is present to indicate that the unit is in standby mode. While in standby all switches are disabled, switch settings are retained and the unit consumes minimal power.

Pressing the power switch brings the unit out of standby (power switch illuminates green). Pressing and holding returns it to standby mode.



The unit can be brought out of standby remotely by connecting pins 1 and 12 on the rear panel D-Type connector.

Mastering Compressor Controls (AM5292)

The 8051 Mastering Compressor is slightly different to the standard 8051 in 2 ways:

- ❑ It has 21 position detented pots for the Trim and Bias controls to aid total mechanical recall of the unit.
- ❑ It has -1dB switches fitted to the Threshold and Gain Make-Up controls to allow for more accurate settings, for example, in a mastering application the entire range of the switches can be turned from 2dB steps into 1dB steps by the selection of the -1dB switches.

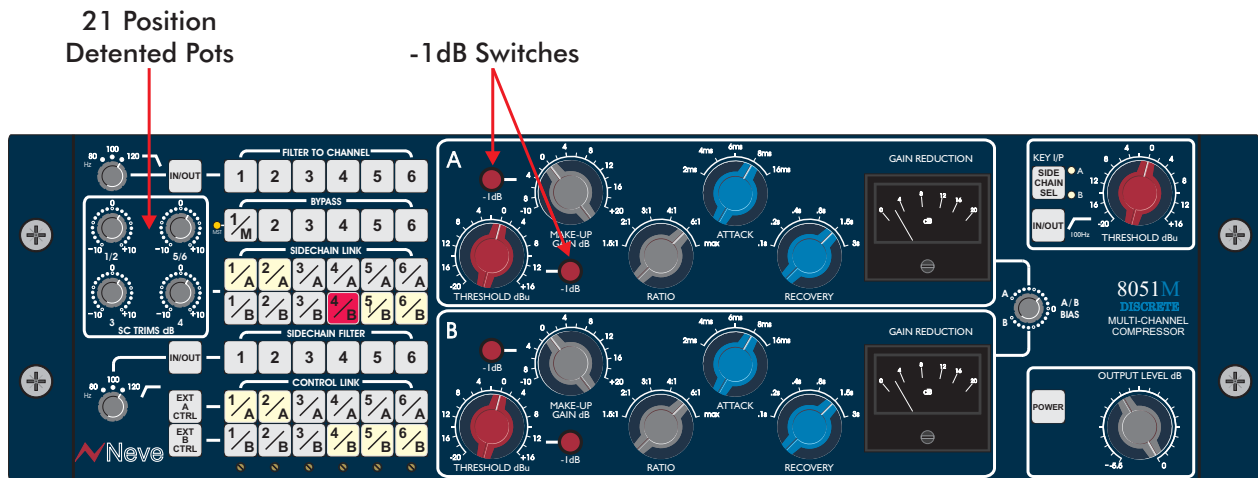

8051 Compressor - 88R(S) Console mounted AM5052



 As this unit is designed for fixed 5.1 compressor applications in an 88R(S) console the EXT A CTRL and EXT B CTRL controls are not selectable (blank buttons).

I/O Wiring (AM5052 & AM5265)**56 Way Free Plug Varicon**

Signal	Signal Name	Pin Number		
		Hi	Lo	Scn
1	1 Left Input	C	J	D
2	3 Centre Input	P	V	K
3	2 Right Input	U	Z	d
4	4 S Input	Y	c	f
5	5 LS Input	s	m	j
6	6 RS Input	x	t	n
7	1 Left Output	CC	y	JJ
8	3 Centre Output	MM	HH	NN
9	2 Right Output	B	F	A
10	4 S Output	L	R	E
11	5 LS Output	S	W	a
12	6 RS Output	X	b	e
13	Key Input	r	l	h
14		v	p	k
15		z	u	DD
16		LL	EE	KK

Specifications

I/O

The key input and LFE filter inputs are electronically balanced with an input impedance of 10kohms. All other inputs are transformer balanced with 3.6kohms input impedances.

All outputs are electronically balanced post the output transformers, with maximum output of +26dBu into 600ohms. The unit is calibrated for bridging loads greater than 10kohms.

Control Voltage I/O is provided for linking multiple units, or linking to 33609 compressors. Connection is by 15 pin D-Type (see the section on EXT control for details).

Audio Performance

Equivalent input noise (20kHz band):	< -78dBu
THD+N (for 20dBu input @1kHz):	< 0.03%
Maximum Output Level:	> 26dBu into 600 ohms
Interchannel Crosstalk:	< -80dB at 15kHz

Control

LFE Filter:	12dB/octave low-pass, -3dB frequency selectable to 80Hz, 100Hz or 120Hz.
Sidechain & Key Filters:	12dB/octave high-pass, -3dB frequency selectable to 80Hz, 100Hz or 120Hz.
Threshold:	-20dBu to +16dBu master control, with ± 15 dB trims on all channels.
Make-up gain:	-10dB to +20dB.
Ratio:	1.5:1, 2:1, 3:1, 4:1, 6:1, MAX (~8:1).
Attack:	2ms, 4ms, 6ms, 8ms and 16ms.
Release:	100ms, 200ms, 400ms, 800ms, 1.5s and 3s.
Output Level Trim:	0dB to -5.5dB pad, in 0.25dB steps.

